

BIOGAS TO BIOMETHANE TECHNOLOGY REVIEW

PRODUCED BY



TECHNISCHE
UNIVERSITÄT
WIEN
Vienna University of Technology



www.thvt.at

VIENNA UNIVERSITY OF TECHNOLOGY (AUSTRIA),
Institute of Chemical Engineering
Research Division Thermal Process Engineering and Simulation

AS PART DELIVERY OF:



Promotion of bio-methane and its market development through local and regional
partnerships

A project under the Intelligent Energy – Europe programme

Contract Number: IEE/10/130
Deliverable Reference: Task 3.1.1
Delivery Date: May 2012

Content

1. Introduction and Overview	3
2. Raw biogas desulphurisation technologies.....	4
2.1. In-situ desulphurisation: Sulphide precipitation.....	4
2.2. Biological desulphurisation: biological scrubbing.....	5
2.3. Chemical-oxidative scrubbing.....	6
2.4. Adsorption on metal oxides or activated carbon	7
3. Biogas upgrading and biomethane production technologies.....	7
3.1. Absorption.....	8
3.1.1. Physical absorption: Pressurised water scrubbing	8
3.1.2. Organic physical absorption.....	9
3.1.3. Chemical absorption: amine scrubbing	9
3.2. Adsorption: Pressure swing adsorption (PSA)	10
3.3. Membrane technology: Gas permeation.....	11
3.4. Comparison of different biogas upgrading technologies.....	12
3.5. Removal of trace components: water, ammonia, siloxanes, particulates.....	14
4. Removal of methane from the offgas.....	14
5. Sources.....	15

1. Introduction and Overview

Biogas upgrading and the production of biomethane nowadays is a state-of-the-art-process of gas separation. A number of different technologies to fulfil the task of producing a biomethane stream of sufficient quality to act as a vehicle fuel or to be injected into the natural gas grid are already commercially available and have proven to be technically and economically feasible. Nevertheless, intensive research is still in progress to optimise and further develop these technologies as well as to apply novel technologies to the field of biogas upgrading. All technologies have their own specific advantages and disadvantages and this review shows, that no technology is the optimal solution to each and every biogas upgrading situation. The right choice of the economically optimal technology is strongly depending on the quality and quantity of the raw biogas to be upgraded, the desired biomethane quality and the final utilisation of this gas, the operation of the anaerobic digestion plant and the types and continuity of the used substrates as well as the local circumstances at the plant site. This choice is to be made by the planner and future operator and this report is worked out to act as a supporting guideline during the planning phase of a new biomethane production site.

As mentioned before, biogas upgrading is a gas separation task finally ending up with a methane-rich product gas stream with a certain specification. Depending on the raw biogas composition this separation task comprises the separation of carbon dioxide (and thus increasing the heating value and Wobbe-Index), the drying of the gas, the removal of trace substances like oxygen, nitrogen, hydrogen sulphide, ammonia or siloxanes as well as the compression to a pressure needed for the further gas utilisation. Furthermore, tasks like odourisation (if injected to a local low-pressure natural gas grid) or adjustment of the heating value by propane-dosing might have to be performed. To give a short overview over the separation task and the involved gas streams a basic flowsheet of biogas upgrading is given in Figure 1.

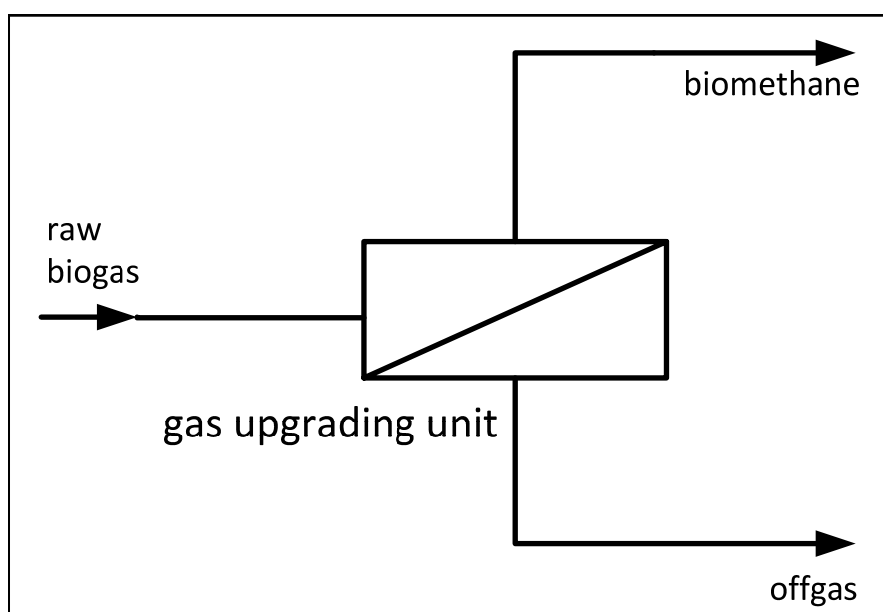

Figure 1: Basic flowsheet of biogas upgrading

The raw biogas basically is split into two gas streams during biogas upgrading: the methane-rich biomethane stream and the carbon-dioxide-rich offgas stream. As no separation technology is perfect, this waste-gas stream still contains a certain amount of methane depending on the methane

recovery of the applied technology. Whether this gas stream is legally permitted to be vented to the atmosphere or has to be further treated is depending on the methane content, on the methane slip of the upgrading plant (amount of methane in the offgas related to the amount of methane in the raw biogas) and on the legal situation at the plant site. The following sections will describe the technologies available for the most important tasks in biogas upgrading (desulphurisation, removal of carbon dioxide, drying). The removal of trace components will be discussed briefly and the possibilities of offgas treatment will be presented at the end of this section.

The following table contains typical gas compositions of biogas and landfill gas and these values are compared to Danish natural gas. The quality of this natural gas seems to be quite representative for available natural gas qualities throughout Europe.

Parameter	Biogas	Landfill gas	Natural gas (Danish)
Methane [vol%]	60-70	35-65	89
Other hydrocarbons [vol%]	0	0	9,4
Hydrogen [vol%]	0	0-3	0
Carbon dioxide [vol%]	30-40	15-50	0,67
Nitrogen [vol%]	up to 1	5-40	0,28
Oxygen [vol%]	up to 0,5	0-5	0
Hydrogen sulphide [ppmv]	0-4000	0-100	2,9
Ammonia [ppmv]	up to 100	up to 5	0
Lower heating value [kWh/m ³ (STP)]	6,5	4,4	11,0

2. Raw biogas desulphurisation technologies

Although carbon dioxide is the major contaminant in the raw biogas during the production of biomethane, it has been shown that the removal of hydrogen sulphide can be of crucial importance for the technological and economic feasibility of the whole gas upgrading chain. Of course, this behaviour strongly depends on the sulphur content of the used substrate and the continuity of the fermentation process. Hydrogen sulphide is a hazardous and corrosive gas that has to be removed from the gas prior to any further utilisation, whether its grid injection or CNG-fuel production. A number of technologies are readily available to fulfil this task. Depending on the local circumstances of the anaerobic digestion plant and the biomethane production unit, one technology or a combination of two or even more technologies for biogas desulphurisation have to be applied to realise a technically stable and economically competitive solution. The most important methods are presented in the following section; the applicability to biogas upgrading for grid injection has been required for this assessment.

2.1. In-situ desulphurisation: Sulphide precipitation

The addition of liquid mixtures of various metal salts (like iron chloride or iron sulphate) to the digester or the mashing tank prior to the digester results in a precipitation of the sulphur content of the substrate by formation of almost insoluble iron sulphide within the biogas fermenter. The iron

sulphide is removed from the fermentation together with the digestate. Additionally to the removal of hydrogen sulphide also ammonia can be removed from the biogas using this technology. Furthermore, it has been reported that an improvement of the liquid milieu for the involved microorganisms can be achieved because of the reduction of toxic substances in the medium. This effect results in an increasing methane yield.

Sulphide precipitation is a relatively cheap desulphurisation method with almost no investment needs. Existing anaerobic digestion plants can be retrofitted with ease and the operation, monitoring and handling is uncomplicated. On the other hand, the degree of desulphurisation is hardly controllable and pro-active measures are not possible. The effectiveness and the achievable biogas quality regarding hydrogen sulphide are clearly limited. This technique is typically used in digesters with high hydrogen sulphide concentrations as a first measure together with subsequent desulphurisation stages or in cases where high amounts of hydrogen sulphide in the biogas are allowed.

The application of this technology to biomethane production is advantageous if:

- Hydrogen sulphide content in untreated biogas would otherwise be moderate or high
- Substrates utilised for biogas production are well known and sulphur potential is known
- No additional investment costs are desired

This technology is advantageous in many cases of biogas and biomethane production as it is cheap and reliable. Furthermore, a certain supply of nutrients and trace components can be facilitated.

2.2. Biological desulphurisation: biological scrubbing

Hydrogen sulphide can be removed through oxidation by chemoautotrophic microorganisms of the species *Thiobacillus* or *Sulfolobus*. This oxidation requires a certain amount of oxygen which is added by a small amount of air (or pure oxygen if levels of nitrogen have to be minimised) to the biological desulphurisation. This oxidation can occur inside the digester by immobilising the microorganisms already available in the natural digestate. The alternative possibility is to use an external apparatus which the biogas passes after leaving the digester. This is the only alternative if biogas upgrading for the production of natural gas substitute is desired. The applied external apparatus is formed as a trickling filter with a packed bed inside which contains the immobilised microorganisms as a biological slime. Biogas is mixed with the added oxidiser, enters the trickling filter and meets a counter flow of water containing nutrients. These microorganisms oxidise hydrogen sulphide with molecular oxygen and convert the unwanted gas compound to water and elemental sulphur or sulphurous acid which is discharged together with the column's waste water stream. The investment needs for this method are moderate and operational costs are low. This technology is widely spread and the plant availability is high.

This method has proven to be simple and stable; the absence of any chemicals involved is a clear advantage. However, long-term operation of this desulphurisation technology together with a biogas upgrading plant in Austria has demonstrated that this method is hardly applicable if a stable grid injection operation is mandatory. The biological system is capable to remove even very high amounts of hydrogen sulphide from the biogas but its adaptability to fluctuating raw biogas hydrogen sulphide contents is significantly poor. Definitely, this technology is not the best choice if high amounts of hydrogen sulphide or fast fluctuations are expected at an anaerobic digestion plant.

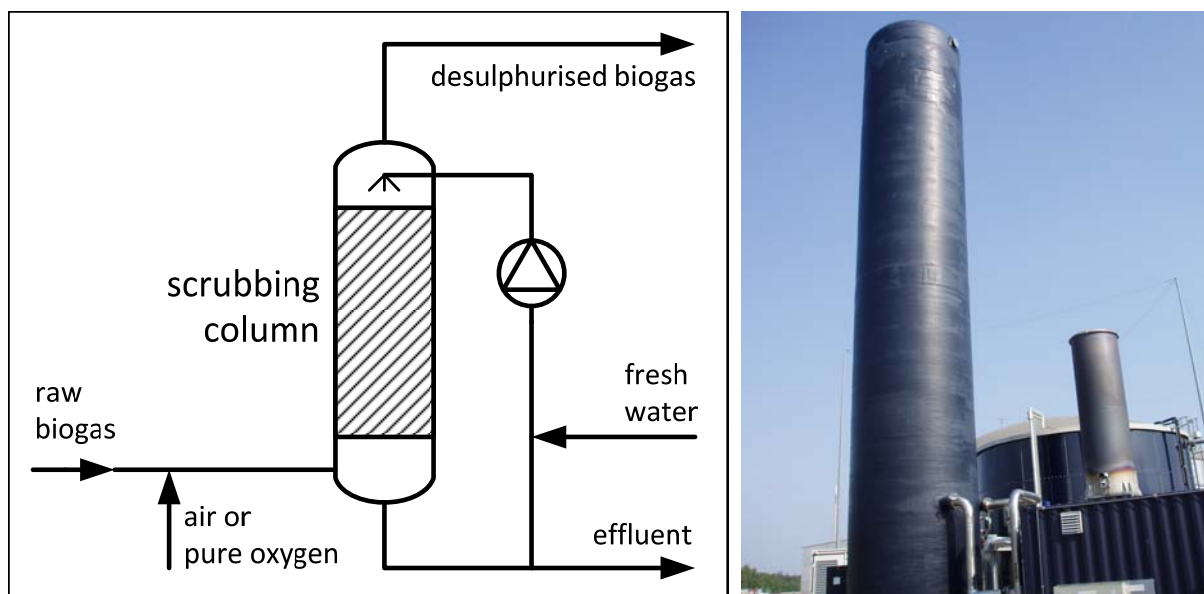

Figure 2: Flowsheet of a biological scrubbing plant for raw biogas desulphurisation; picture of the biological scrubber at the biogas plant Bruck/Leitha, Austria with a raw biogas capacity of 800m³/h (Source: Vienna University of Technology, Biogas Bruck GmbH)

The application of this technology to biomethane production is advantageous if:

- Hydrogen sulphide content in raw biogas is low or moderate
- Fluctuations in hydrogen sulphide content of raw biogas are weak
- Substrates utilised for biogas production are not changing frequently
- Nitrogen input to biogas is unobjectionable for further biogas upgrading or
- Pure oxygen is easily accessible for oxidation purposes instead of air
- Biological scrubber is already available at biogas plant and operation has to be switched to pure oxygen only

2.3. Chemical-oxidative scrubbing

The absorption of hydrogen sulphide in caustic solutions is one of the oldest methods for gas desulphurisation. Nowadays, typically sodium hydroxide is used as a caustic and the pH is carefully controlled to adjust the separation selectivity. The task is to create and maintain a plant operation with maximised hydrogen sulphide absorption and minimised carbon dioxide absorption in order to minimise chemical consumption (carbon dioxide is to be removed with a more efficient technology). The selectivity of hydrogen sulphide versus carbon dioxide can be further increased by the application of an oxidiser to oxidise the absorbed hydrogen sulphide to elemental sulphur or sulphate, thus increasing the rate of hydrogen sulphate removal. Usually hydrogen peroxide is used as an oxidiser in biogas upgrading plants. This technique shows favourable controllability and stable operation even under strong fluctuations of raw biogas quality and quantity. Hydrogen sulphide contents of as low as 5ppm can be reached during stable operation. Usually, the most economic operation is to control the content of the purified gas to be around 50ppm; the remaining hydrogen sulphide is removed by means of adsorption on metal oxides. This technology requires elaborate process control and the knowledge of dealing with the used chemical agents. It has been reported that the specific costs of this technology is highly competitive to other existing desulphurisation technologies. This technology has to be considered if high or strongly fluctuating hydrogen sulphide contents have to be expected at a biomethane production site.

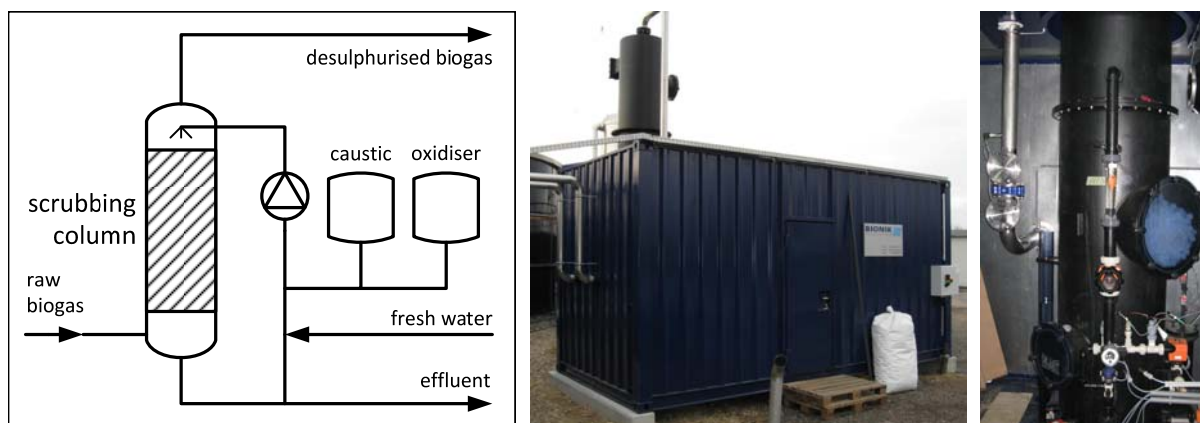

Figure 3: Flowsheet of a chemical-oxidative scrubbing plant for raw biogas desulphurisation; pictures of the chemical-oxidative scrubber at the biogas plant Bruck/Leitha, Austria with a raw biogas capacity of 300m³/h (Source: Vienna University of Technology, Biogas Bruck GmbH)

The application of this technology to biomethane production is advantageous if:

- Hydrogen sulphide content in raw biogas is moderate or high
- Fluctuations in hydrogen sulphide content of raw biogas are moderate or high
- Substrates utilised for biogas production are changing frequently or often
- Any addition of oxygen or nitrogen to raw biogas is disadvantageous for further biogas upgrading
- Highly automated and reliable operation and low labour efforts are desired
- Handling with chemical agents is no operational obstacle for personnel

2.4. Adsorption on metal oxides or activated carbon

Hydrogen sulphide can be adsorbed on the surface of metal oxides like iron oxide, zinc oxide or copper oxide or on activated carbon and excellently removed from the biogas. During the adsorption on metal oxides the sulphur is bound as metal sulphide and water vapour is released. As soon as the adsorbent material is loaded it is removed and replaced by fresh material. The adsorption of hydrogen sulphide on activated carbon usually is performed with a small addition of oxygen in order to oxidise the adsorbed gas to sulphur and to bind it stronger to the surface. If no oxygen dosing is allowed, a specially impregnated activated carbon material is applied. This desulphurisation technique is extremely efficient with resulting concentrations of less than 1ppm. Although the investment costs are relatively low the overall specific costs of this technology are considerably high with the result that this method typically is applied only for final and fine desulphurisation tasks (typically up to 150ppm hydrogen sulphide in the raw biogas).

The application of this technology to biomethane production is advantageous if:

- Hydrogen sulphide content in raw biogas is low or
- Technology is used for final desulphurisation only

3. Biogas upgrading and biomethane production technologies

Currently, a number of different technologies for the major biogas upgrading step are commercially available. This major step comprises the drying of the raw biogas and the removal of carbon dioxide, and thus, the enhancement of the heating value of the produced gas. These proved technologies will be presented in the following section. Afterwards, the removal of minor or trace components from

the raw biogas will be discussed. Typically, these removal steps are already included in any commercially available biogas upgrading plant.

3.1. Absorption

The separation principle of absorption is based on different solubilities of various gas components in a liquid scrubbing solution. In an upgrading plant using this technique the raw biogas is intensively contacted with a liquid within a scrubbing column filled with a plastic packing in order to increase the contact area between the phases. The components to be removed from the biogas (mostly carbon dioxide) are typically far more soluble in the applied liquid than methane and are removed from the gas stream. As a result, the remaining gas stream is enriched with methane and the scrubbing liquid leaving the column is rich in carbon dioxide. In order to maintain the absorption performance, this scrubbing liquid has to be replaced by fresh liquid or regenerated in a separated step (desorption or regeneration step). Currently, three different upgrading technologies embodying this physical principle are available.

3.1.1. Physical absorption: Pressurised water scrubbing

The absorbed gas components are physically bound to the scrubbing liquid, in this case water. Carbon dioxide has a higher solubility in water than methane and will therefore be dissolved to a higher extent, particularly at lower temperatures and higher pressures. In addition to carbon dioxide, also hydrogen sulphide and ammonia can be reduced in the biomethane stream using water as a scrubbing liquid. The effluent water leaving the column is saturated with carbon dioxide and is transferred to a flash tank where the pressure is abruptly reduced and the major share of the dissolved gas is released. As this gas mainly contains carbon dioxide, but also a certain amount of methane (methane is also soluble in water, but to a smaller extent) this gas is piped to the raw biogas inlet. If the water is to be recycled back to the absorption column, it has to be regenerated and is therefore pumped to a desorption column where it meets a counter current flow of stripping air, into which the remaining dissolved carbon dioxide is released. The regenerated water is then pumped back to the absorber as fresh scrubbing liquid.

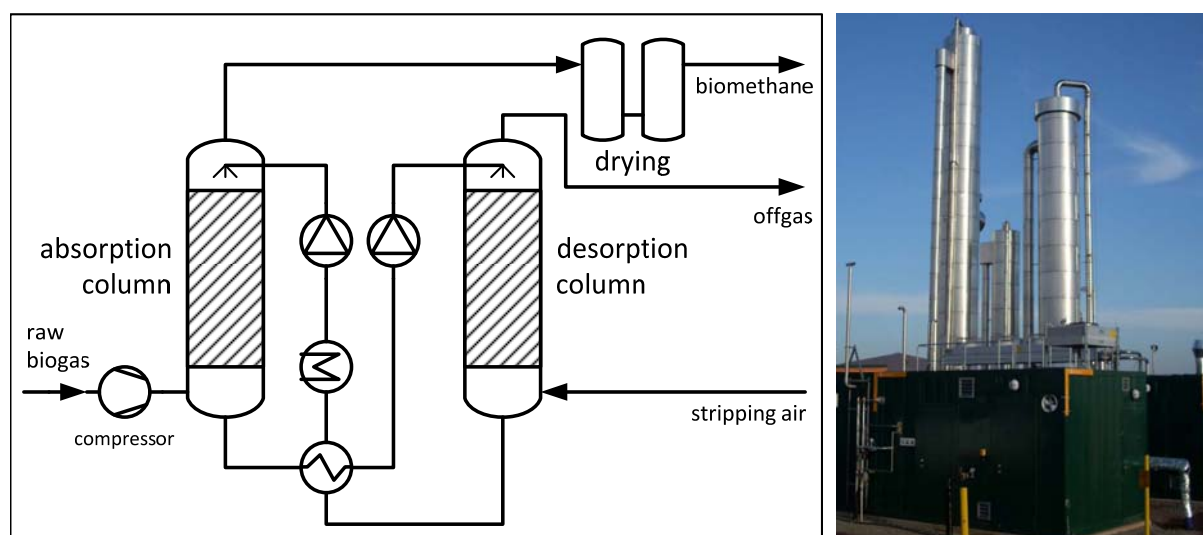

Figure 4: Flowsheet of a typical biogas upgrading unit applying pressurised water scrubbing; picture of the upgrading plant Könnern, Germany with a raw biogas capacity of 1250m³/h (Source: Malmberg)

The drawback of this method is that the air components oxygen and nitrogen are dissolved in the water during regeneration and thus, transported to the upgraded biomethane gas stream. Therefore, biomethane produced with this technology always contains oxygen and nitrogen. As the produced biomethane stream is saturated with water, the final step in upgrading typically is gas drying, for example by the application of glycol scrubbing.

The application of this technology to biomethane production is advantageous if:

- Oxygen and nitrogen content in biomethane together with a reduced heating value is tolerable
- Projected plant capacity is medium or large
- Biomethane stream can directly be utilised at delivery pressure and no further compression is needed
- Heat demand of the biogas plant can be (partly) covered by offgas treatment

3.1.2. Organic physical absorption

Very similar to water scrubbing, this technology uses an organic solvent solution (e.d. polyethylene glycol) instead of water as a scrubbing liquid. Carbon dioxide shows higher solubilities in these solvents than in water. As a result, less scrubbing liquid circulation and smaller apparatuses are needed for the same raw biogas capacity. Examples of commercially available biogas upgrading technologies implementing organic physical scrubbing are Genosorb[®], Selexol[®], Sepasolv[®], Rektisol[®] and Purisol[®].

3.1.3. Chemical absorption: amine scrubbing

Chemical absorption is characterised by a physical absorption of the gaseous components in a scrubbing liquid followed by a chemical reaction between scrubbing liquid components and absorbed gas components within the liquid phase. As a result, the bonding of unwanted gas components to the scrubbing liquid is significantly stronger and the loading capacity of the scrubbing liquid is several times higher. The chemical reaction is strongly selective and the amount of methane also absorbed in the liquid is very low resulting in very high methane recovery and very low methane slip. Due to the high affinity of especially carbon dioxide to the used solvents (mainly aqueous solutions of Monoethanolamine MEA, Diethanolamine DEA and Methyldiethanolamine MDEA) the operating pressure of amine scrubbers can be kept significantly smaller compared to pressurised water scrubbing plants of similar capacity.

Typically, amine scrubbing plants are operated at the slightly elevated pressure already provided in the raw biogas and no further compression is needed. The high capacity and high selectivity of the amine solution, although an advantage during absorption, turns out to be a disadvantage during the regeneration of the scrubbing solution. Chemical scrubbing liquids require a significantly increased amount of energy during regeneration which has to be provided as process heat. The loaded amine solution is heated up to about 160°C where most of the carbon dioxide is released and leaves the regeneration column as a considerably pure offgas stream. As a small part of the scrubbing liquid is lost to the produced biomethane due to evaporation, it has to be replenished frequently. Hydrogen sulphide could also be absorbed from the raw biogas by chemical absorption but higher temperatures during regeneration would be needed. That is why it is advisable to remove this component prior to the amine scrubber.

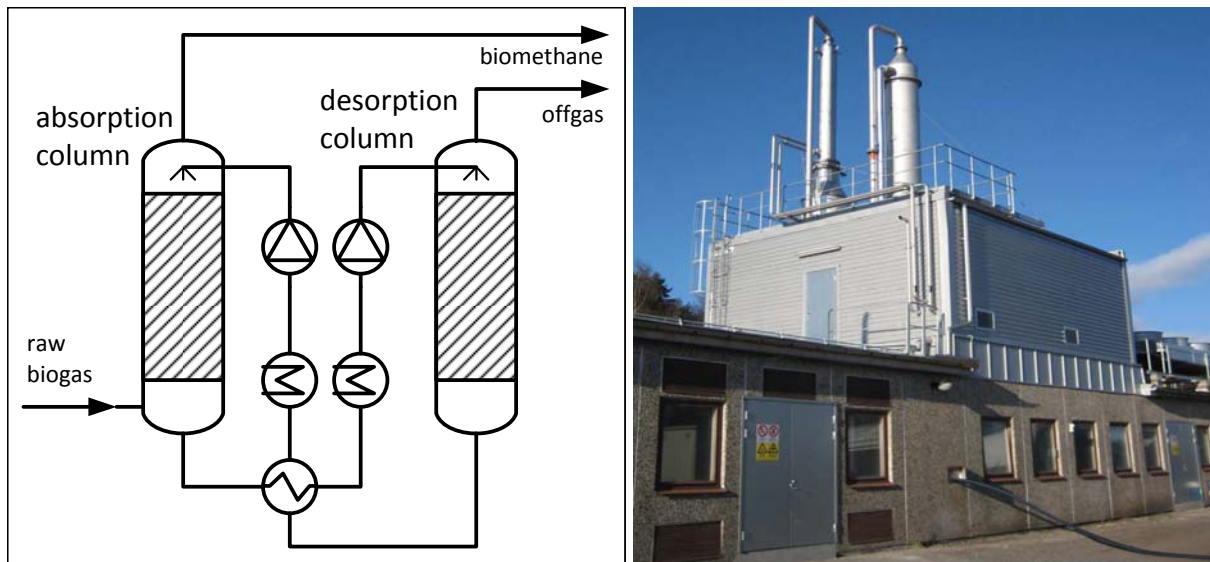

Figure 5: Flowsheet of a typical biogas upgrading unit applying amine scrubbing; picture of the upgrading plant Gothenburg, Sweden with a raw biogas capacity of 1600m³/h (Source: Cirmac)

The application of this technology to biomethane production is advantageous if:

- High methane recovery is desired and consequently, no further offgas treatment to reduce the methane emissions is necessary
- High methane content of biomethane stream is desired
- Projected plant capacity is medium or large
- Biomethane stream can be utilised at the almost atmospheric delivery pressure and no further compression is needed
- Heat demand of regeneration step can be covered by infrastructure available at biogas plant

3.2. Adsorption: Pressure swing adsorption (PSA)

Gas separation using adsorption is based on different adsorption behaviour of various gas components on a solid surface under elevated pressure. Usually, different types of activated carbon or molecular sieves (zeolites) are used as the adsorbing material. These materials selectively adsorb carbon dioxide from the raw biogas, thus enriching the methane content of the gas. After the adsorption at high pressure the loaded adsorbent material is regenerated by a stepwise decrease in pressure and flushing with raw biogas or biomethane. During this step offgas is leaving the adsorber. Afterwards, the pressure is increased again with raw biogas or biomethane and the adsorber is ready for the next sequence of loading. Industrial scale upgrading plants implement four, six or nine adsorber vessels in parallel at different positions within this sequence in order to provide a continuous operation. During the decompression phase of the regeneration the composition of the offgas is changing as the also adsorbed methane is released earlier (at higher pressures) and the bulk of carbon dioxide is preferentially desorbed at lower pressures. Thus, the offgas of the first steps of decompression is typically piped back to the raw biogas inlet in order to reduce the methane slip. Offgas from later steps of regeneration could be led to a second stage of adsorption, to the offgas treatment unit or could be vented to the atmosphere. As water and hydrogen sulphide contents in the gas irreversibly harm the adsorbent material these components have to be removed before the adsorption column.

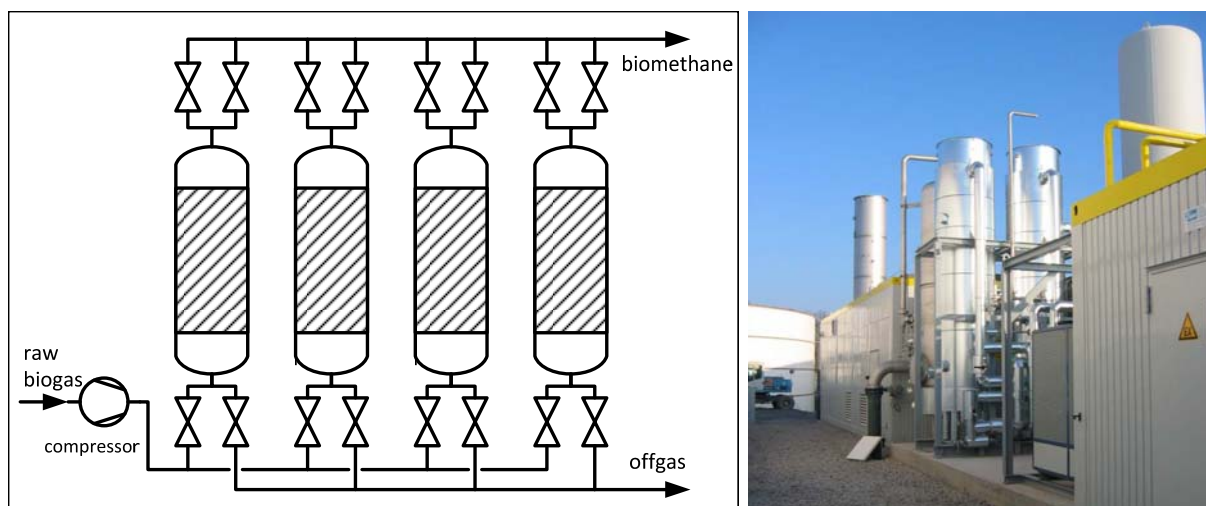

Figure 6: Flowsheet of a typical biogas upgrading unit applying pressure swing adsorption; picture of the upgrading plant Mühlacker, Germany with a raw biogas capacity of 1000m³/h (Source: Schmack CARBOTECH)

The application of this technology to biomethane production is advantageous if:

- Methane content of biomethane stream (95,0-99,0vol%) is suitable for further utilisation
- Projected plant capacity is small or medium
- Biomethane stream can directly be utilised at delivery pressure and no further compression is needed
- Heat demand of the biogas plant can be (partly) covered by offgas treatment

3.3. Membrane technology: Gaspermeation

Membranes for biogas upgrading are made of materials that are permeable for carbon dioxide, water and ammonia. Hydrogen sulphide, oxygen and nitrogen permeate through the membrane to a certain extent and methane passes only to a very low extent. Typical membranes for biogas upgrading are made of polymeric materials like polysulfone, polyimide or polydimethylsiloxane. These materials show favourable selectivity for the methane/carbon dioxide separation combined with a reasonable robustness to trace components contained in typical raw biogases. To provide sufficient membrane surface area in compact plant dimensions these membranes are applied in form of hollow fibers combined to a number of parallel membrane modules.

After the compression to the applied operating pressure the raw biogas is cooled down for drying and removal of ammonia. After reheating with compressor waste heat the remaining hydrogen sulphide is removed by means of adsorption on iron or zinc oxide. Finally, the gas is piped to a single- or multi-staged gaspermeation unit. The numbers and interconnection of the applied membrane stages are not determined by the desired biomethane quality but by the requested methane recovery and specific compression energy demand. Modern upgrading plants with more complex design offer the possibility of very high methane recoveries and relatively low energy demand. Even multi-compressor arrangements have been realised and proved to be economically advantageous. The operation pressure and compressor speed are both controlled to provide the desired quality and quantity of the produced biomethane stream.

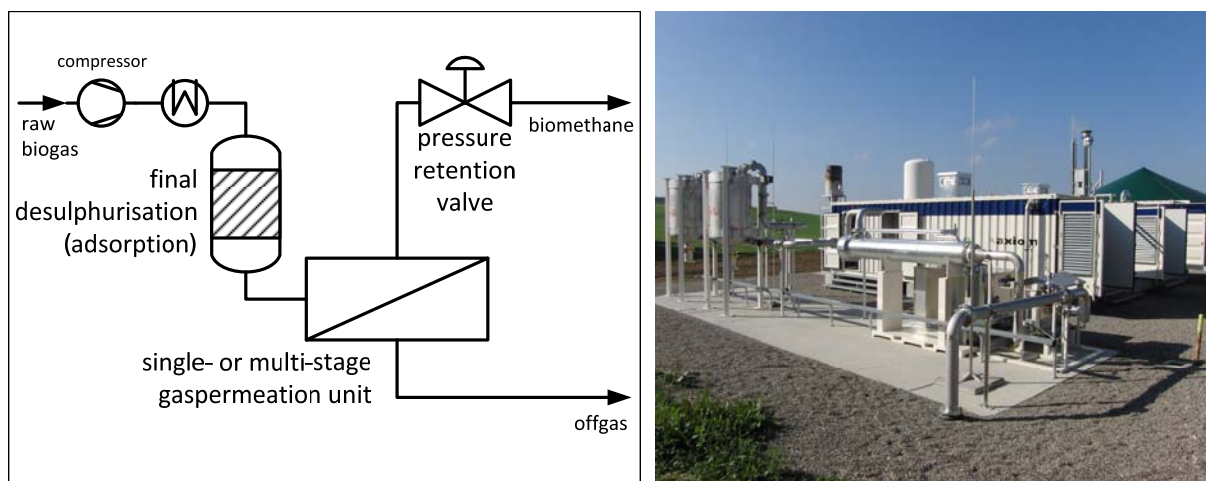

Figure 7: Flowsheet of a typical biogas upgrading unit applying the membrane technology gaspermeation; picture of the upgrading plant Kisslegg, Germany with a raw biogas capacity of 500m³/h (Source: AXIOM Angewandte Prozesstechnik)

The application of this technology to biomethane production is advantageous if:

- High flexibility towards process layout and adaption to the local biogas production facility as well as flexible partial load behaviour and plant dynamics are desired
- Methane content of biomethane stream (95,0-99,0vol%) is suitable for further utilisation
- Projected plant capacity is small or medium
- Biomethane stream can directly be utilised at delivery pressure and no further compression is needed
- Heat demand of the biogas plant can be (partly) covered by offgas treatment or
- Additional chemicals and other consumables have to be avoided
- Fast Start-up from cold standby and Start/Stop operation have to be realised

3.4. Comparison of different biogas upgrading technologies

It is hard to give a universally valid comparison of the different biogas upgrading technologies because many essential parameters strongly depend on local circumstances. Furthermore, the technical possibilities of a certain technology (for example regarding the achievable biomethane quality) often do not correspond with the most economic operation. The technical development of most biogas upgrading methods nowadays is typically sufficient to meet any needs of a potential plant operator. It's only a question of finding a plant design providing the most economic operation of biomethane production. As a result, it is strongly recommended to perform a detailed analysis of the specific biomethane costs to be expected and to account for all possible upgrading technologies. As a guiding tool to fulfil these tasks the "BiomethaneCalculator" has been developed during this project and will be updated every year. This tool contains all relevant upgrading steps and upgrading technologies and allows for a qualified estimation of specific biomethane production costs to be expected.

The following table summarises the most important parameters of the described biogas upgrading technologies applied to a typical raw biogas composition. Values of certain parameters represent averages of realised upgrading plants or verified data from literature. The price basis used is March 2012.

Membrane technology offers the possibility to widely adapt the plant layout to the local circumstances by the application of different membrane configurations, multiple membrane stages and multiple compressor variations. This is why a certain range is given for most of the parameters. The first number always corresponds to the simpler plant layout (“cheaper” and with low methane recovery) while the other number corresponds to a high recovery plant layout.

Parameter	Water scrubbing	Organic physical scrubbing	Amine scrubbing	PSA	Membrane technology
typical plant size range [m ³ /h biomethane]	200-1.200	300-1.500	400-2.000	300-800	50-500
typical methane content in biomethane [vol%]	95,0-99,0	95,0-99,0	>99,0	95,0-99,0	95,0-99,0
methane recovery [%]	98,0	96,0	99,96	98	80-99,5
methane slip [%]	2,0	4,0	0,04	2,0	20-0,5
typical delivery pressure [bar(g)]	4-8	4-8	0	4-7	4-7
electric energy demand [kWhel/m ³ biomethane]	0,46	0,49-0,67	0,27	0,46	0,25-0,43
heating demand and temperature level	-	medium 70-80°C	high 120-160°C	-	-
desulphurisation requirements	process dependent	yes	yes	yes	yes
consumables demand	antifouling agent, drying agent	organic solvent (non-hazardous)	amine solution (hazardous, corrosive)	activated carbon (non-hazardous)	
partial load range [%]	50-100	50-100	50-100	85-115	50-105
number of reference plants	high	low	medium	high	low
typical investment costs [€/(m ³ /h) biomethane]					
for 100m ³ /h biomethane	10.100	9.500	9.500	10.400	7.300-7.600
for 250m ³ /h biomethane	5.500	5.000	5.000	5.400	4.700-4.900
for 500m ³ /h biomethane	3.500	3.500	3.500	3.700	3.500-3.700
typical operational costs [ct/m ³ biomethane]					
for 100m ³ /h biomethane	14,0	13,8	14,4	12,8	10,8-15,8
for 250m ³ /h biomethane	10,3	10,2	12,0	10,1	7,7-11,6
for 500m ³ /h biomethane	9,1	9,0	11,2	9,2	6,5-10,1

3.5. Removal of trace components: water, ammonia, siloxanes, particulates

Biogas is saturated with water vapour when it leaves the digester. This water tends to condensate in apparatuses and pipelines and together with sulphur oxides may cause corrosion. By increasing the pressure and decreasing the temperature water will condense from the biogas and can thereby be removed. Cooling can either be realised by using the surroundings temperature (air, soil) or by electric cooling (refrigeration). Water can also be removed by scrubbing with glycol or by adsorption on silicates, activated charcoal or molecular sieves (zeolites).

Ammonia is usually separated when the biogas is dried by cooling as its solubility in liquid water is high. Furthermore, most technologies for carbon dioxide removal are also selective for the removal of ammonia. A separate cleaning step is therefore usually not necessary.

Siloxanes are used in products such as deodorants and shampoos, and can therefore be found in biogas from sewage sludge treatment plants and landfill gas. These substances can create serious problems when burned in gas engines or combustion facilities. Siloxanes can either be removed by gas cooling, by adsorption on activated carbon, activated aluminium or silica gel or by absorption in liquid mixtures of hydrocarbons.

Particulates and droplets can be present in biogas and landfill gas and can cause mechanical wear in gas engines, turbines and pipelines. Particulates that are present in the biogas are separated by fine mechanical filters (0,01µm – 1µm).

4. Removal of methane from the offgas

As mentioned before, the offgas produced during biogas upgrading still contains a certain amount of methane depending on the methane recovery of the applied gas separation technology. As methane is a strong greenhouse gas, it is of vital importance for the overall sustainability of the biomethane production chain to minimise the methane emissions to the atmosphere. It has to be mentioned, that the emissions of methane from biogas processing plants is limited in most countries. Additionally, higher amounts of methane in the offgas increase the specific upgrading costs and could inhibit an economic plant operation. But it's not that simple as there is a trade-off in selecting a certain methane recovery value because a higher methane recovery always increases investment and operational costs of a certain upgrading technology. As a result, the most promising plant layout in terms of economics usually accepts a certain amount of methane left in the offgas and applies a certain treatment of the gas prior to venting it to the atmosphere.

The most common technique of removing the methane content in the offgas is the oxidation (combustion) and generation of heat. This heat can either be consumed at the anaerobic digestion plant itself (as this plant often has a heat demand), it can be fed to a district heating system (if locally available) or it has to be wasted by cooling. Another possibility would be to mix the offgas with raw biogas and feed it to an existing CHP gas engine. Either way, the layout of the plant has to be planned carefully as the offgas of a modern biogas upgrading plant seldom contains enough methane to maintain a flame without addition of natural gas or raw biogas.

Alternatively, the methane in the offgas can be oxidised by a low-calorific combustor or by catalytic combustion. A number of manufacturers already provide applicable technologies on a commercial

basis. These systems provide stable combustion even at methane contents of as low as 3% in the combustion mixture with air. The treatment of offgas containing even less methane is increasingly difficult as not enough energy is provided during the combustion of this gas and raw biogas or biomethane have to be added in order to reach a stable oxidation. This is why it does not make sense to choose an upgrading technology with a methane recovery as high as possible because you always have to deal with the offgas. The integration of the upgrading plant into the biogas production facility and the overall concept of the biomethane production site are much more important. Only very few upgrading technologies with extremely high methane recoveries provide an offgas that is permitted to be directly vented to the atmosphere.

5. Sources

"Abschlussbericht Verbundprojekt Biogaseinspeisung, Band 4"
Fraunhofer-Institut fuer Umwelt-, Sicherheits- und Energietechnik UMSICHT
Urban, Lohmann, Girod; Germany, 2009
www.umsicht.fraunhofer.de

"Biogas upgrading technologies - developments and innovations"
IEA Bioenergy Task 37 - Energy from biogas and landfill gas
Peterson, Wellinger; Sweden & Switzerland, 2009
www.iea-biogas.net

"Biogas upgrading to vehicle fuel standards and grid injection"
IEA Bioenergy Task 37 - Energy from biogas and landfill gas
Persson, Jönsson, Wellinger; Sweden & Switzerland, 2006
www.iea-biogas.net

"Biogas upgrading and utilisation"
IEA Bioenergy Task 24 - Energy from biological conversion of organic waste
Lindberg, Wellinger; Sweden & Switzerland, 2006
www.iea-biogas.net

"Techniques for transformation of biogas to biomethane"
Biomass and Bioenergy 35 (2011) 1633-1645
Ryckebosch, Drouillon, Vervaeren; 2011
www.journals.elsevier.com/biomass-and-bioenergy

"Membrane biogas upgrading processes for the production of natural gas substitute"
Separation and Purification Technology 74 (2010) 83–92
Makaruk, Miltner, Harasek; 2010
www.journals.elsevier.com/separation-and-purification-technology

"Chemical-oxidative scrubbing for the removal of hydrogen sulphide from raw biogas: potentials and economics"
Water Science and Technology (2012) to be published
Miltner, Makaruk, Krischan, Harasek; 2012
www.iwaponline.com/wst/default.htm